

## Wings & Wheels Wing Stand Kit cutting and assembly instructions



The stands as supplied are typically too tall for most glider assembly purposes and need to be cut down and the final assembly completed.

\* uncut these are tall enough for assembly aids for many tall high wing gliders and some tow seaters that require very tall stands.

This is all very easy to do but here are a few tips on how I have done them in the past.

### Step 1.

Start by removing the three legs, you need only a Phillips screwdriver and a 10mm wrench, remove the legs at the top tri-support and the support beams.

### Step 2.

*(Measure twice, cut once!)*

Measure 6 5/8" from the top of each leg post for the new hole location, measure 6" from the **TOP** of each leg post for the cut off line, Drill a new 1/4" hole exactly in the center of the tube and exactly in line with the original top tri-mount and bottom support beam holes.

### Step 3.

Drill the new top tri-mount holes. I used to cut the legs first and then drill the tubes afterwards but find it is far more accurate and easier to drill the new holes first using the original holes for and then remove making sure I keep all holes in exact alignment and then cut the tube afterwards



It's important that the new top bolt holes are aligned parallel to the support beam holes so if you have a drill press, clamp the tube lightly with the drill in the existing support beam hole lined up vertically to help insure when you make the (new) top mount hole it will be aligned with the original holes.



This can also be done easily with a hand drill but you will want to pay close attention to be sure it is in line.



#### Step 4.

Cut 6 inches\*\* from the **TOP** of each leg, I use and suggest a simple low cost Tube cutter like the one pictured normally used by plumbers for cutting PVC pipe but a saw or other tube cutter will work. The tubes are very thin and lightweight so cut slowly and let the tools do the work and don't force them.

#### Step 5.

*Skipping this step is optional  
the center post will be quite close to the ground (even  
Before making modifications) so the legs should be  
Spread not much more than about 30-35 degrees out  
When in use (much stronger this way anyway!) If you  
Want to modify these stands further to allow a greater  
Spread of the legs; simply re-drill the support beams (flat  
Bars connecting the legs to center post)*

Measure 2" on the support beam both the hole centerline and drill a new hole with 1/4" drill, measure from the top of the beam the new cut-up length and remove this extra material length. File and finish the ends smooth



#### Step 6.

Now you can reassemble the legs and support beams

#### Step 7.

##### Center post shortening

remove the center post tube clamp by Loosening the screw and handle .  
With the center post clamp and (telescoping tube section) removed, measure and cut \* about 7 inches from the top.

\* (You can remove less if you want a taller stand but be careful not to remove much over 7" or the tube clamp will not fit on or allow the stand to fold for storage!)

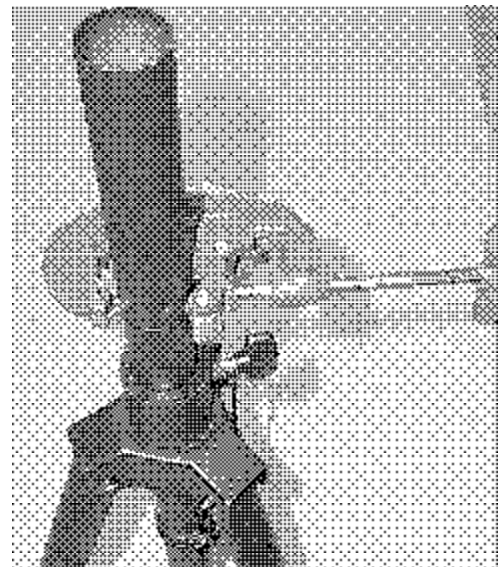



Remove and burrs from the inside of the tube where you previously cut and shortened this so the inner tube will easily fit in and slide. You can do this with the tube cutting tool if it has the attachment or simply use a half round file.

**Step 8.**

The Final cutting step is to cut again about 7 inches from the BOTTOM of the center (Sliding portion) tube.

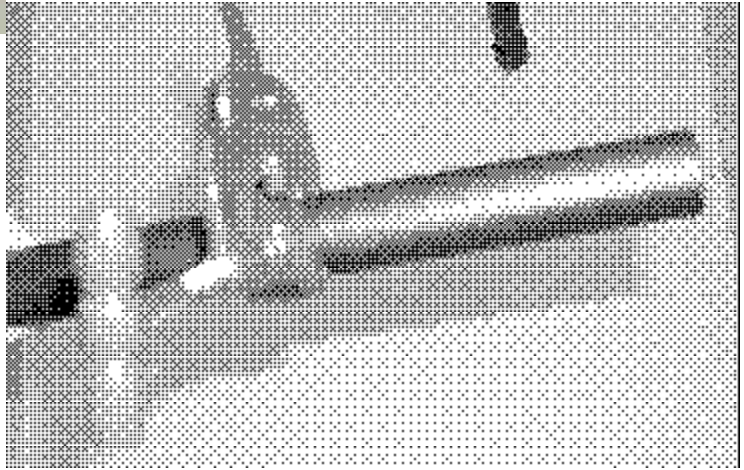

After removing this section, use a screwdriver handle or dowel to knock out the plastic center cap from the bottom of the tube. Replace this cap in your shortened center tube. All tube cutting is now completed.

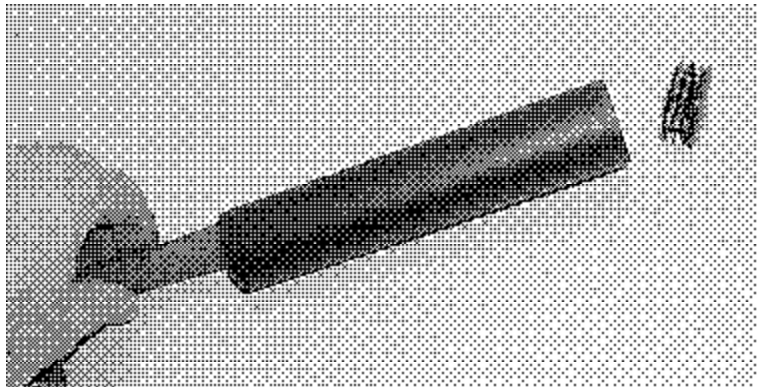

You will note there is a small spring and plastic cap that reside in the bottom of the main (larger) center tube these rest on the screws at the bottom of the tube and serve as a cushion only for the tube, being as they are, rather light and flimsy you may leave them out or replace them later with another plug or block of wood....not really essential.

## Top plate and wing cushion

### Step 9.

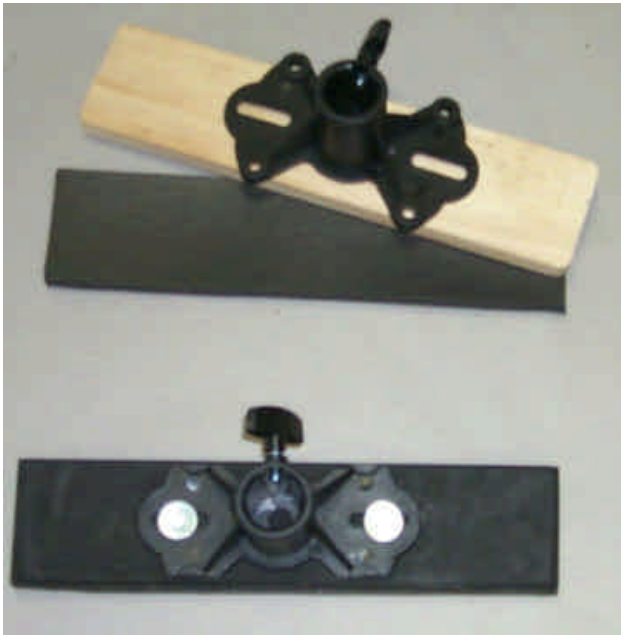

The final assembly is attaching the board to the top piece. The “ears” can be removed by cutting or grinding if you want a more finished top piece. There are two Wood Anchor nuts included for attaching the plate to the top piece. Simply drill through the board completely a hole large enough for these to be present into place. Use the supplied bolts and large diameter washers to attach the parts.

The top foam pad can easily be attached with contact adhesive like the type used for installing formica counter tops.

**All steps are now complete!**



You may note that these stands are sometimes black, sometimes silver depending on what my suppliers have to offer, they may also have some minor differences in hardware but all can be modified similarly and the dimensions given in these instructions can also be modified slightly to have a taller or shorter stand as you may wish, just be sure to keep everything dimensionally similar to what I have described here.

These stands are light but in normal use I have found them to be more sturdy and stable than any other wing stand offered anywhere. If, however you any cracking in the tube, loose bolts or hardware, you should replace these parts or make repairs before using them. Any one small part can cause the entire stand to collapse possibly damaging an expensive wing or doing other harm. Without completing **Step #5** you

may notice that in use if the legs are spread too far apart the center post will come in contact with the ground, the stand will be far stronger with the legs “less apart” since all loads will be placed above the stand legs in a more linear position. I make no claim to the strength of the stand after you make your modifications. The responsibility for safe use is entirely up to the user, with this in mind and using normal care these lightweight stands should be more than strong enough and offer several years of normal use.

